



# Operating Instructions and Parts Manual

## 16-Inch Woodworking Band Saw

Model JWBS-16B



**JET**  
427 New Sanford Road  
LaVergne, Tennessee 37086  
Ph.: 800-274-6848  
[www.jettools.com](http://www.jettools.com)

**Part No. M-708749B**  
Revision A2 05/2014  
Copyright © 2014 JET

# Warranty and Service

JET® warrants every product it sells against manufacturers' defects. If one of our tools needs service or repair, please contact Technical Service by calling 1-800-274-6846, 8AM to 5PM CST, Monday through Friday.

## Warranty Period

The general warranty lasts for the time period specified in the literature included with your product or on the official JET branded website.

- JET products carry a limited warranty which varies in duration based upon the product. (See chart below)
- Accessories carry a limited warranty of one year from the date of receipt.
- Consumable items are defined as expendable parts or accessories expected to become inoperable within a reasonable amount of use and are covered by a 90 day limited warranty against manufacturer's defects.

## Who is Covered

This warranty covers only the initial purchaser of the product from the date of delivery.

## What is Covered

This warranty covers any defects in workmanship or materials subject to the limitations stated below. This warranty does not cover failures due directly or indirectly to misuse, abuse, negligence or accidents, normal wear-and-tear, improper repair, alterations or lack of maintenance.

## Warranty Limitations

Woodworking products with a Five Year Warranty that are used for commercial or industrial purposes default to a Two Year Warranty. Please contact Technical Service at 1-800-274-6846 for further clarification.

## How to Get Technical Support

Please contact Technical Service by calling 1-800-274-6846. **Please note that you will be asked to provide proof of initial purchase when calling.** If a product requires further inspection, the Technical Service representative will explain and assist with any additional action needed. JET has Authorized Service Centers located throughout the United States. For the name of an Authorized Service Center in your area call 1-800-274-6846 or use the Service Center Locator on the JET website.

## More Information

JET is constantly adding new products. For complete, up-to-date product information, check with your local distributor or visit the JET website.

## How State Law Applies

This warranty gives you specific legal rights, subject to applicable state law.

## Limitations on This Warranty

JET LIMITS ALL IMPLIED WARRANTIES TO THE PERIOD OF THE LIMITED WARRANTY FOR EACH PRODUCT. EXCEPT AS STATED HEREIN, ANY IMPLIED WARRANTIES OF MERCHANTABILITY AND FITNESS FOR A PARTICULAR PURPOSE ARE EXCLUDED. SOME STATES DO NOT ALLOW LIMITATIONS ON HOW LONG AN IMPLIED WARRANTY LASTS, SO THE ABOVE LIMITATION MAY NOT APPLY TO YOU.

JET SHALL IN NO EVENT BE LIABLE FOR DEATH, INJURIES TO PERSONS OR PROPERTY, OR FOR INCIDENTAL, CONTINGENT, SPECIAL, OR CONSEQUENTIAL DAMAGES ARISING FROM THE USE OF OUR PRODUCTS. SOME STATES DO NOT ALLOW THE EXCLUSION OR LIMITATION OF INCIDENTAL OR CONSEQUENTIAL DAMAGES, SO THE ABOVE LIMITATION OR EXCLUSION MAY NOT APPLY TO YOU.

JET sells through distributors only. The specifications listed in JET printed materials and on official JET website are given as general information and are not binding. JET reserves the right to effect at any time, without prior notice, those alterations to parts, fittings, and accessory equipment which they may deem necessary for any reason whatsoever. JET® branded products are not sold in Canada by JPW Industries, Inc.

## Product Listing with Warranty Period

90 Days – Parts; Consumable items; Light-Duty Air Tools
1 Year – Motors; Machine Accessories; Heavy-Duty Air Tools; Pro-Duty Air Tools
2 Year – Metalworking Machinery; Electric Hoists, Electric Hoist Accessories
5 Year – Woodworking Machinery
Limited Lifetime – JET Parallel clamps; VOLT Series Electric Hoists; Manual Hoists; Manual Hoist Accessories; Shop Tools; Warehouse & Dock products; Hand Tools

NOTE: JET is a division of JPW Industries, Inc. References in this document to JET also apply to JPW Industries, Inc., or any of its successors in interest to the JET brand.

# Table of Contents

Warranty and Service.....	2
Table of Contents .....	3
Warning .....	4
Introduction.....	6
Specifications .....	6
Grounding Instructions .....	7
Unpacking .....	8
Contents of Shipping Container .....	8
Assembly and Setup .....	9
Base Support Extension .....	9
Adjusting Blade Tension.....	10
Adjusting Blade Tracking.....	10
Lower Blade Guide Adjustment.....	11
Mounting the Table.....	12
Rail Assembly (optional accessory) .....	13
Fence Assembly and Adjustment (optional accessory) .....	13
Resaw Guide (optional accessory).....	14
Miter Gauge (optional accessory) .....	14
Tilting the Table.....	15
Height Scale Adjustment .....	15
Changing Blades .....	16
Replacing V-Belt.....	17
Adjusting Belt Tension.....	17
Electrical Connections .....	18
Maintenance .....	18
Upper Blade Guide Adjustment.....	10
Troubleshooting .....	19
Parts .....	19
Replacement Parts .....	19
Upper Wheel Assembly .....	20
Lower Wheel and Motor Assembly.....	22
Blade Guides Assembly .....	24
Table Assembly .....	26
Fence & Miter Assembly (optional accessory) .....	28
Wiring Diagram .....	30



# Warnings

1. Read and understand the entire owner's manual before attempting assembly or operation.
2. Read and understand the warnings posted on the machine and in this manual. Failure to comply with all of these warnings may cause serious injury.
3. Replace the warning labels if they become obscured or removed.
4. This band saw is designed and intended for use by properly trained and experienced personnel only. If you are not familiar with the proper and safe operation of a band saw, do not use until proper training and knowledge have been obtained.
5. Do not use this band saw for other than its intended use. If used for other purposes, JET, disclaims any real or implied warranty and holds itself harmless from any injury that may result from that use.
6. Always wear approved safety glasses/face shields while using this band saw. Everyday eyeglasses only have impact resistant lenses; they are not safety glasses.
7. Before operating this band saw, remove tie, rings, watches and other jewelry, and roll sleeves up past the elbows. Remove all loose clothing and confine long hair. Non-slip footwear or anti-skid floor strips are recommended. Do not wear gloves.
8. Wear ear protectors (plugs or muffs) during extended periods of operation.
9. Some dust created by power sanding, sawing, grinding, drilling and other construction activities contain chemicals known to cause cancer, birth defects or other reproductive harm. Some examples of these chemicals are:
  - Lead from lead based paint.
  - Crystalline silica from bricks, cement and other masonry products.
  - Arsenic and chromium from chemically treated lumber.

Your risk of exposure varies, depending on how often you do this type of work. To reduce your exposure to these chemicals, work in a well-ventilated area and work with approved safety equipment, such as face or dust masks that are specifically designed to filter out microscopic particles.
10. Do not operate this machine while tired or under the influence of drugs, alcohol or any medication.
11. Make certain the switch is in the OFF position before connecting the machine to the power supply.
12. Make certain the machine is properly grounded.
13. Make all machine adjustments or maintenance with the machine unplugged from the power source.
14. Remove adjusting keys and wrenches. Form a habit of checking to see that keys and adjusting wrenches are removed from the machine before turning it on.
15. Keep safety guards in place at all times when the machine is in use. If removed for maintenance purposes, use extreme caution and replace the guards immediately.
16. Check damaged parts. Before further use of the machine, a guard or other part that is damaged should be carefully checked to determine that it will operate properly and perform its intended function. Check for alignment of moving parts, binding of moving parts, breakage of parts, mounting and any other conditions that may affect its operation. A guard or other part that is damaged should be properly repaired or replaced.
17. Provide for adequate space surrounding work area and non-glare, overhead lighting.
18. Keep the floor around the machine clean and free of scrap material, oil and grease.
19. Keep visitors a safe distance from the work area. **Keep children away.**



## Warnings

20. Make your workshop child proof with padlocks, master switches or by removing starter keys.
21. Give your work undivided attention. Looking around, carrying on a conversation and “horse-play” are careless acts that can result in serious injury.
22. Maintain a balanced stance at all times so that you do not fall or lean against the blade or other moving parts. Do not overreach or use excessive force to perform any machine operation.
23. Use the right tool at the correct speed and feed rate. Do not force a tool or attachment to do a job for which it was not designed. The right tool will do the job better and safer.
24. Use recommended accessories; improper accessories may be hazardous.
25. Maintain tools with care. Keep blades sharp and clean for the best and safest performance. Follow instructions for lubricating and changing accessories.
26. Turn off the machine before cleaning. Use a brush or compressed air to remove chips or debris — do not use your hands.
27. Do not stand on the machine. Serious injury could occur if the machine tips over.
28. Never leave the machine running unattended. Turn the power off and do not leave the machine until it comes to a complete stop.
29. Remove loose items and unnecessary work pieces from the area before starting the machine.

**Familiarize yourself with the following safety notices used in this manual:**

**CAUTION** This means that if precautions are not heeded, it may result in minor injury and/or possible machine damage.

**WARNING** This means that if precautions are not heeded, it may result in serious injury or possibly even death.

**- - SAVE THESE INSTRUCTIONS - -**

## Introduction

This manual is provided by JET, covering the safe operation and maintenance procedures for model JWBS-16B Band Saw. This manual contains instructions on installation, safety precautions, general operating procedures, maintenance instructions and parts breakdown. This machine has been designed and constructed to provide years of trouble free operation if used in accordance with instructions set forth in this manual. If there are any questions or comments, please contact either your local supplier or JET. JET can also be reached at our web site: [www.jettools.com](http://www.jettools.com).

## Specifications

Stock Number .....	708749B
Cutting Capacity (height).....	10"
Cutting Capacity (width).....	16-3/8"
Maximum Rip Left of Blade w/Fence .....	14-1/4"
Blade Length .....	123"
Blade Speed.....	3000 SFPM
Minimum Blade Width .....	1/8"
Maximum Blade Width .....	1-1/2"
Table Size .....	17" x 17"
Table Tilt.....	45°R to 10°L
Table Height from Floor .....	35"
Wheel Diameter .....	16-1/2"
Dust Chute Diameter.....	4"
Dust Collection Minimum CFM.....	400
Overall Dimensions .....	68" H x 31-1/2" W x 26-3/8" D
Motor .....	TEFC 1-1/2 HP, 1PH, 115/230V, <b>prewired 115V</b>
Net Weight (approx.) .....	317 lbs.
Shipping Weight (approx.).....	340 lbs.

The specifications in this manual are given as general information and are not binding. JET reserves the right to effect, at any time and without prior notice, changes or alterations to parts, fittings, and accessory equipment deemed necessary for any reason whatsoever.

# Grounding Instructions

**⚠ WARNING** This machine must be grounded while in use to protect the operator from electric shock.

In the event of a malfunction or breakdown, grounding provides a path of least resistance for electric current to reduce the risk of electric shock. This machine is equipped with an electric cord having an equipment-grounding conductor and a grounding plug. The plug must be plugged into a matching outlet that is properly installed and grounded in accordance with all local codes and ordinances.

Do not modify the plug provided. If it will not fit the outlet, have the proper outlet installed by a qualified electrician.

Improper connection of the equipment-grounding conductor can result in a risk of electric shock. The conductor, with insulation having an outer surface that is green with or without yellow stripes, is the equipment-grounding conductor. If repair or replacement of the electric cord or plug is necessary, do not connect the equipment-grounding conductor to a live terminal.

Check with a qualified electrician or service personnel if the grounding instructions are not completely understood, or if in doubt as to whether the tool is properly grounded. Use only three wire extension cords that have three-prong grounding plugs and three-pole receptacles that accept the tool's plug.

Repair or replace a damaged or worn cord immediately.

## Model JWBS-16B

Model JWBS-16B Band Saw has a 1-3/4 HP 1 phase motor and is wired from the factory for 115 volt operation, but can be rewired for 230 volts.

## 115 Volt Operation

The JWBS-16B Band Saw comes equipped with a *plug* that looks like A, Fig. 1. and is used in an *outlet* that looks like B, Fig. 1. A *temporary adapter* with a *grounding ear* secured with a *screw* (C, Fig. 1) may be used to connect this plug to a two-pole receptacle if a properly grounded outlet is not available. The temporary adapter should only be used until a properly grounded outlet can be installed by a qualified electrician. **This adapter is not applicable in**

**Canada.** The green colored *grounding ear*, lug, or tab, extending from the adapter, must be connected to a permanent ground such as a properly grounded outlet box, as shown in C, Fig. 1.

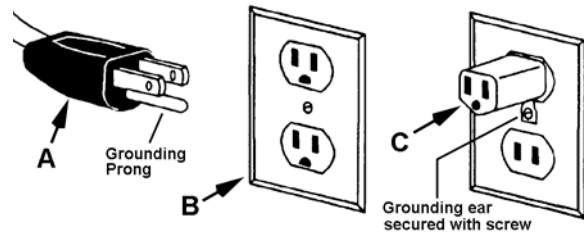

Figure 1

## 230 Volt Operation

To convert the JWBS-16B from 115V to 230V, single phase operation, the following is strongly recommended:

Contact your local Authorized JET Service Center or qualified electrician for proper procedures to install the plug. The band saw must comply with all local and national codes after the 230V plug is installed.

The 115V attachment plug supplied with the band saw (C, Fig. 2) must be replaced with a UL/CSA listed plug suitable for 230V operation (D, Fig. 2).

The band saw with a 230V plug should only be connected to an outlet having the same configuration (D, Fig. 2). No adapter is available or should be used with the 230V plug.

**Important:** In all cases (115 or 230 volts), make certain the receptacle in question is properly grounded. If you are not sure, have a registered electrician check the receptacle.

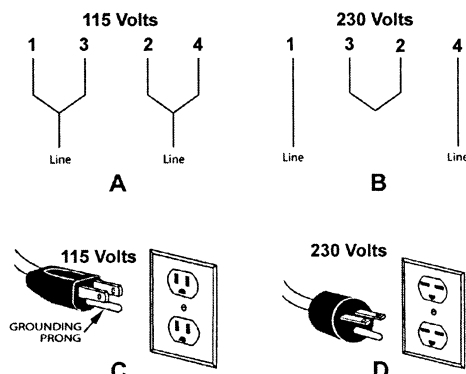

Figure 2

## Unpacking

Remove the packing material from the band saw.

**Note:** Remove the plywood and bolts from the base. Inspect the machine for damage. Report any damage to your distributor and shipping agent.

Move the saw to its permanent working location. The site should be dry, well lit, and have enough room to handle long stock and the service and/or adjustment of the machine from any side.

Move the band saw off the skid. Clean all rust protected surfaces with a mild solvent or diesel fuel and a soft cloth. Do not use lacquer thinner, paint thinner, or gasoline. These will damage painted surfaces.

## Contents of Shipping Container

- 1 - Band Saw
- 1 - Table
- 1 - Owner's Manual
- 1 - Warranty Card
- 1 - Accessory Package Contains:
  - 2 - Extension Straps
  - 1 - Extension Base
- 1 - Accessory Package Includes:
  - 2 - Knobs
  - 1 - 5mm Hex Wrench
  - 1 - 4mm Hex Wrench
  - 1 - Handle
  - 1 - 10/12mm Wrench
  - 1 - 12/14mm Wrench
  - 1 - Trunnion Support Bracket
    - 4 - Hex Cap Bolts 5/16"-18x1-1/2"
    - 4 - Lock Washers 5/16"
  - 8 - 5/16-18 x 3/8 Button Hd. Cap Screws
  - 8 - 5/16 Flat Washers

## Tools Included for Assembly

- 1 - 10/12mm Open End Wrench
- 1 - 12/14mm Open End Wrench
- 1 - 5mm Hex Wrench

## Tools Required for Assembly & Adjustments

- 1 - Combination Square
- 1 - Cross Point Screw Driver





# Assembly and Setup

## Base Support Extension

1. Attach straps (A, Fig. 1A) to extension base (B, Fig. 1A) with (2) 5/16-18 button head cap screws (C, Fig. 1A) and with (2) 5/16 flat washers (D, Fig. 1A). If needed punch holes through striping decal. NOTE: Leave screws slightly loose.

2. Repeat for opposite end of extension base.

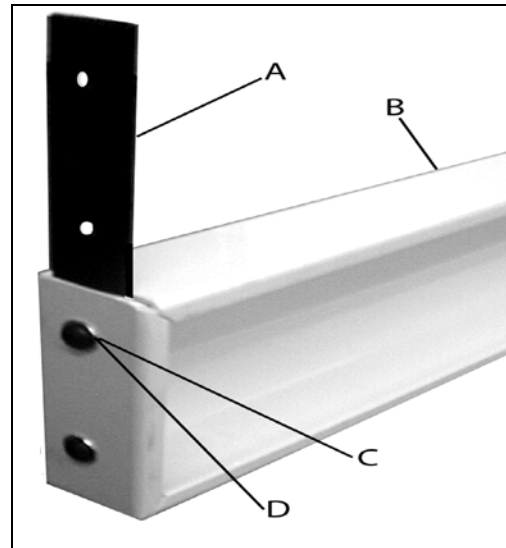

Figure 1A

3. Insert straps through slits in base of machine lining up holes in machine base with tapped holes in strap (Fig 1B)

4. Attach straps to machine base using (2) 5/16-18 button head Cap screw (E, Fig. 1C) and (2) 5/16 flat washers (F, Fig. 1C).

5. Repeat for opposite end of extension base.



Figure 1B

6. Tighten all (8) button head cap screws with the 5 MM hex wrench provided.

7. Attach the handle (C, Fig. 2) to the hand wheel (D, Fig. 2).

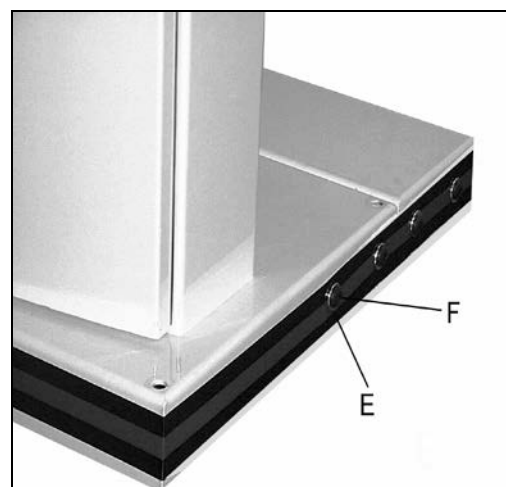

Figure 1C

## Adjusting Blade Tension

1. Disconnect machine from the power source, unplug.
2. Turn blade tension hand wheel (E, Fig. 2) counter-clockwise to tension blade, and clockwise to loosen the tension. A gauge on the upper wheel slide bracket (F, Fig. 2) indicates the approximate tension according to the width of the blade. The JWBS-16B comes with a 3/4" blade so the tension should be set at 3/4" when using this blade.

As you become familiar with the saw, you may find it necessary to change the blade tension from the initial setting. Changes in blade width, and the type of material being cut will have an effect on blade tension.

Keep in mind that too little, or too much blade tension can cause blade breakage and/or poor cutting performance.

## Adjusting Blade Tracking

**WARNING** Disconnect machine from the power source! Never adjust blade tracking with the machine running! Failure to comply may cause serious injury!

**Note:** Blade tracking has been adjusted at the factory. If, however, it is determined that blade tracking needs adjustment:

1. Blade must be properly tensioned before adjusting blade tracking. Make sure upper and, lower blade guides do not interfere with the blade while adjusting the tracking.
2. Open the upper wheel door. Rotate the wheel forward, and observe the position of the blade on the wheel. The blade should rest in approximately the center of the wheel.
3. If adjustment is necessary, loosen the wing nut (G, Fig. 2) at the top rear of the saw.
4. Adjust tracking by turning the knob (H, Fig. 2) in 1/4 turn increments. Rotate the wheel forward, and observe the position of the blade on the wheel. Rotating knob (H, Fig. 2) counter-clockwise should move the blade towards the front of the wheel. Rotating the knob clockwise should move the blade towards the back of the wheel.
5. Continue with adjustments until the blade is tracking properly.
6. Tighten the wing nut (G, Fig. 2).

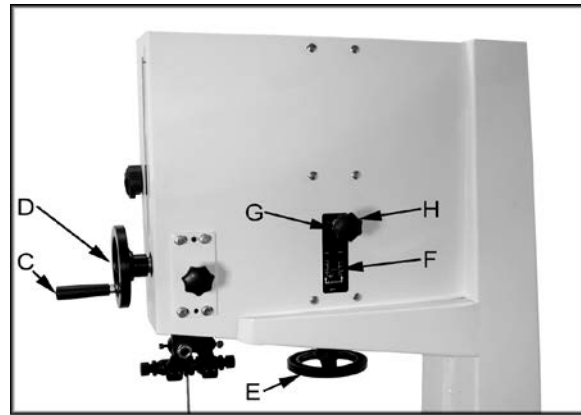

Figure 2

## Upper Blade Guide Adjustment

**WARNING** Disconnect machine from the power source, unplug before making any adjustments! Blade teeth are sharp! Use care when working near the saw blade. Failure to comply may cause serious injury!

1. Blade tension and tracking must be properly adjusted prior to blade guide setup.
2. The blade guard has been removed in Figure 3 for photo purposes only.
3. Loosen the socket head cap screw (A, Fig. 3) and position the blade guide assembly (B, Fig. 3) so that the guides rest just behind the gullet of the blade teeth. Tighten the socket head cap screw.
4. Loosen lock nuts (D, Fig. 3).
5. Adjust guide knobs (E, Fig. 3) so guides (C, Fig. 3) rest lightly against the blade. Do not force the guides against the side of the blade. Tighten both lock nuts.
6. Adjust the blade support bearing so that it is 0.003" away from the back of the blade, about the thickness of a piece of paper. To make this adjustment loosen wing nut (F, Fig. 3) and slide the bearing and bearing post into position. Tighten wing nut.

**Note:** Blade support bearing should be adjusted so that the back edge of the blade overlaps the front face of the ball bearing by approximately 1/8". If adjustment is needed loosen wing nut (F, Fig. 3) and turn the bearing shaft. Tighten wing nut.

## Lower Blade Guide Adjustment

**⚠WARNING** Disconnect machine from the power source, unplug before making any adjustments! Blade teeth are sharp! Use care when working near the saw blade. Failure to comply may cause serious injury!

1. Blade tension and tracking must be properly adjusted prior to blade guide setup.
2. The blade guard has been removed in Figure 4 for photo purposes only.
3. Loosen the socket head cap screws (G, Fig. 4) and position the blade guide assembly (H, Fig. 4) so that the guides rest just behind the gullet of the blade teeth. Tighten the socket head cap screws.
4. Loosen thumb screw (I, Fig. 4). Adjust guides (J, Fig. 4) so they rest lightly against the blade. Do not force the guide against the side of the blade. Tighten thumb screw.
5. Adjust the blade support bearing so that it is 0.003" away from the back of the blade, about the thickness of a piece of paper. To make this adjustment loosen wing nut (K, Fig. 4) and slide the bearing and bearing post into position. Tighten wing nut.

**Note:** Blade support bearing should be adjusted so that the back edge of the blade overlaps the front face of the ball bearing by approximately 1/8". If adjustment is needed loosen wing nut (K, Fig. 4) and turn the bearing shaft. Tighten wing nut.

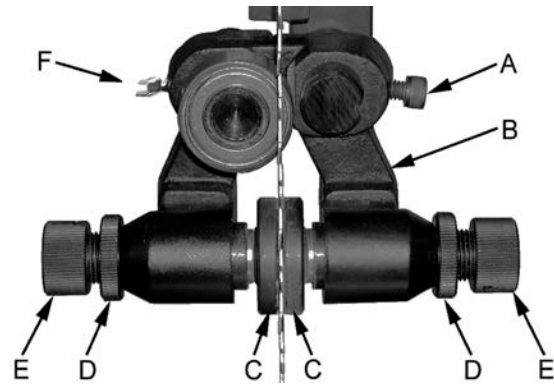

Figure 3

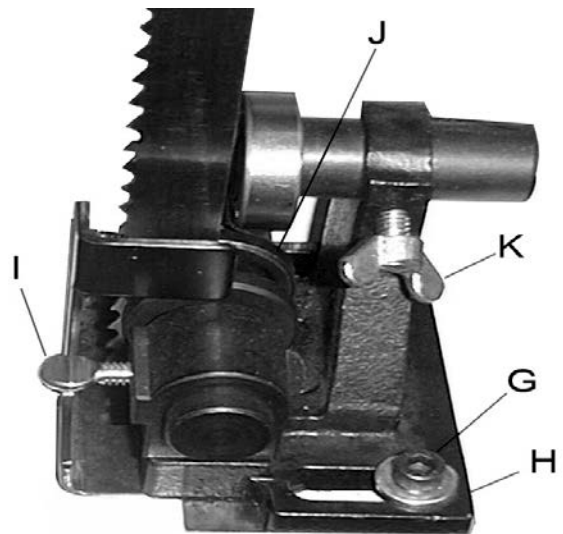

Figure 4

## Mounting the Table

1. Mount the trunnion support bracket (A, Fig. 5) to the bandsaw with four 5/16" x 1-1/2" hex cap bolts, and four 5/16" lock washers (B, Fig. 5).
2. Remove the round table insert (C, Fig. 5) found where the blade goes through the table. Also, remove the table pin (D, Fig. 5) found on the side of the table.
3. Slide saw blade through slot in table where the table pin was located. Rotate the table 90 degrees so that the miter slot is parallel to the blade, and to the right of the blade when facing the bandsaw.
4. Line up the trunnions so that the bolts feed through the trunnion support bracket. Secure the table with two lock knobs (C, Fig. 6). Reinstall the table insert and table pin.
5. Place a square (E, Fig. 5) on the table and against the back edge of the blade. If the table needs adjusted, on the low side, loosen two bolts (B, Fig. 5) and turn the setscrew (F, Fig. 5) until the table is approximately square to the back edge of the blade.

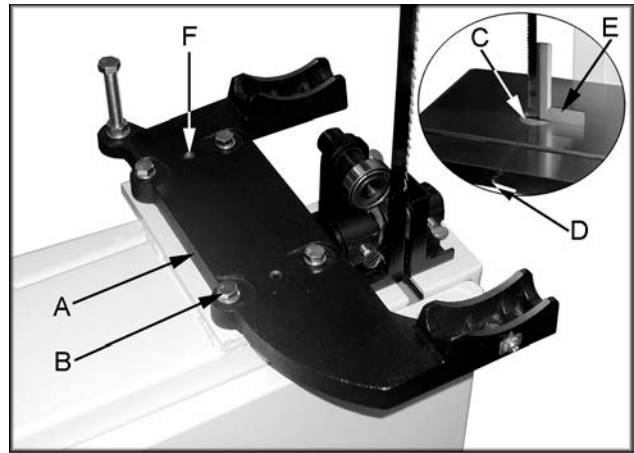

Figure 5

## Adjusting 90 Degree Table Stop

1. Blade tension and tracking must be properly adjusted prior to table stop setup.
2. Loosen lock knobs (C, Fig. 6) and tilt table until it rests against table stop bolt (D, Fig. 6). Tighten knobs.
3. Use a square (G, Fig. 7) placed on the table and against the blade to see if the table is 90 degrees to the blade.
4. If an adjustment is necessary, loosen the lock knobs. Tilt the table until it is square to the blade, and tighten the lock knobs.
5. Loosen lock nut (E, Fig. 6) and turn table stop bolt (D, Fig. 6) until it contacts the table. Tighten the nut (E, Fig. 6) to hold table stop in place. When tightening the nut hold the table stop bolt in place with a wrench to prevent movement.
6. If necessary, adjust pointer (F, Fig. 6) to zero.

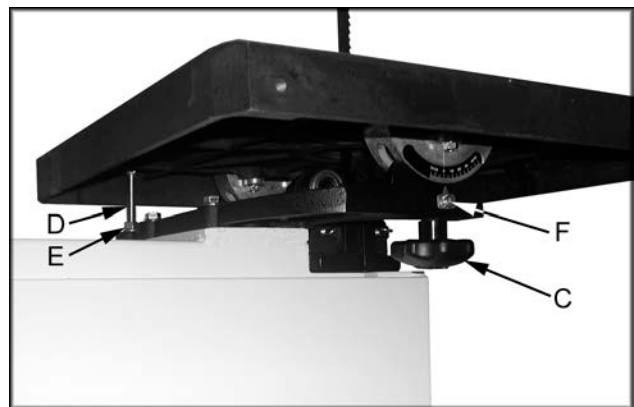

Figure 6

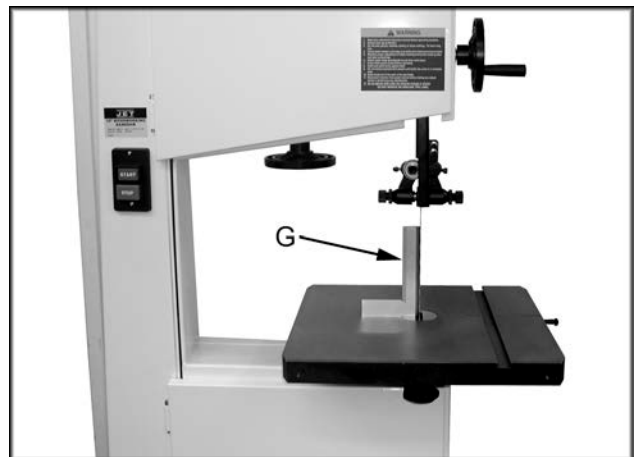

Figure 7

### Rail Assembly (optional accessory)

1. Attach the front rail (A, Fig. 8) to the cast iron table with two 1/4" x 5/8" hex cap bolts, two 1/4" lock washers, and two 1/4" flat washers. Bolts should be in approximately the center of the slot. Hand tighten only at this time.
2. Attach the rear rail (B, Fig. 8) to the table with two 1/4" x 5/8" hex cap bolts, two 1/4" lock washers, and two 1/4" flat washers. Bolts should be in approximately the center of the slot. Hand tighten only at this time.
3. Push the front, and rear rails up as far as they will go.
4. Tighten the four hex cap bolts holding the front, and rear rails to the table. Do not over tighten the bolts.
5. Attach the guide tube (C, Fig. 8) to the front rail with five 1/4" x 5/8" hex cap bolts, five 1/4" lock washers, and five 1/4" flat washers. Bolts should be in approximately the center of the slot.

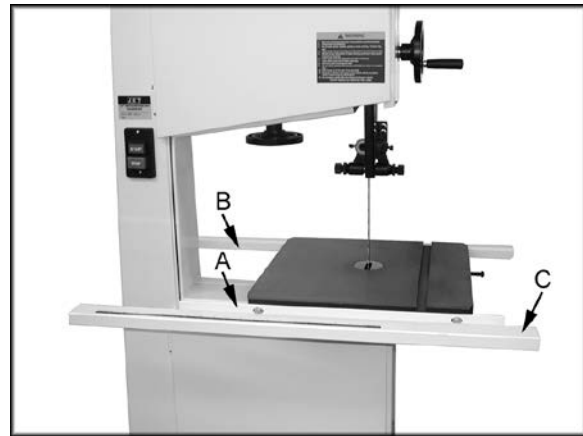

Figure 8

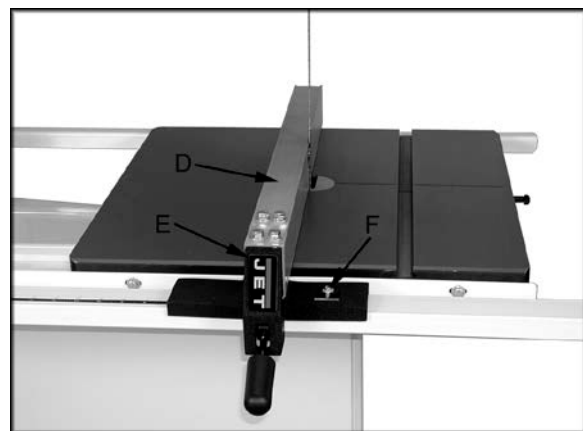

Figure 9

### Fence Assembly and Adjustment (optional accessory)

1. Attach the fence (D, Fig. 9) to the fence body (E, Fig. 9) with four 5/16" x 3/4" hex cap bolts, four 5/16" lock washers, and four 5/16" flat washers.
2. Thread a hex nut (G, Fig. 10) onto the pad's threaded stud (H, Fig. 10) and insert through the fence and rear hook (I, Fig. 10). Secure in place using a hex nut, lock washer and flat washer (J, Fig. 10).

**Note:** The hook should be adjusted so that it overlaps the rear rail by approximately 1/8".

3. Place fence assembly onto the guide tube. The rear hook should engage the rear rail.

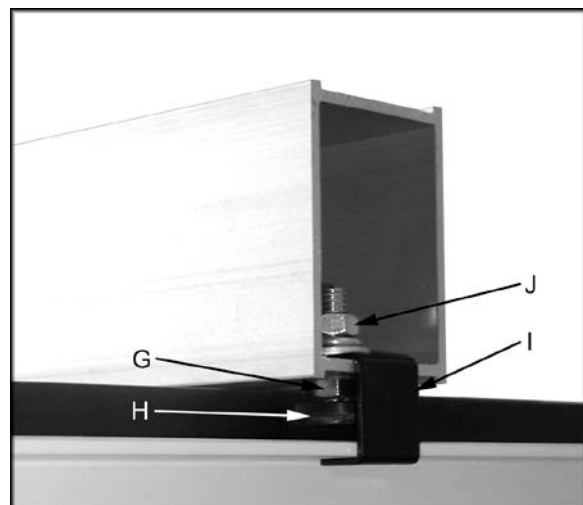

Figure 10

4. Check the clearance between the table and the fence. The gap should be the same at the front of the table as it is at the rear. If the gap width is different, adjust the foot at the rear of the fence until the gap width is the same, Figure 11.

**Note:** You can also adjust the front rail or rear rail up, or down to achieve the proper clearance.

5. With a square verify the fence face is perpendicular to the table top. If it is not the front rail will need to be adjusted parallel to the table top. This can be accomplished by measuring from the top of the table to the top of the front rail. The measurement should be the same at both ends of the table.
6. Move the fence assembly so that it aligns parallel to the blade, and lock the fence by pushing the lock handle down.
7. Loosen the four hex cap bolts that hold the fence, to the fence body, and align the fence to the blade. Tighten the four hex cap bolts.
8. Check to see that the pointer (F, Fig. 9) is aligned with the zero marking on the guide rail. If adjustment is necessary loosen the screw that holds the pointer in place and line up to the zero mark. Tighten the screw.

**Note:** If you cannot get the pointer lined up with the zero mark you can slide the guide tube and front rail left, or right to achieve the proper setting.

### Resaw Guide (optional accessory)

For resawing attach the post (A, Fig. 12) to fence with the lock knob (B, Fig. 12). There is a slotted hole in the fence that will accommodate the resaw kit. Position the post so that it is centered with the front edge of the blade. The resaw guide will give you a taller, single point contact surface during resawing.

### Miter Gauge (optional accessory)

1. Place the miter gauge in the table slot.
2. With a square verify the miter gauge face is square to the blade.
3. If the miter gauge is not square to the blade loosen the lock knob (C, Fig. 12) and adjust to the proper setting. Tighten the lock knob.
4. If the pointer is not at 90 degrees, loosen the screw (D, Fig. 12) holding the pointer and move the pointer to 90 degrees.

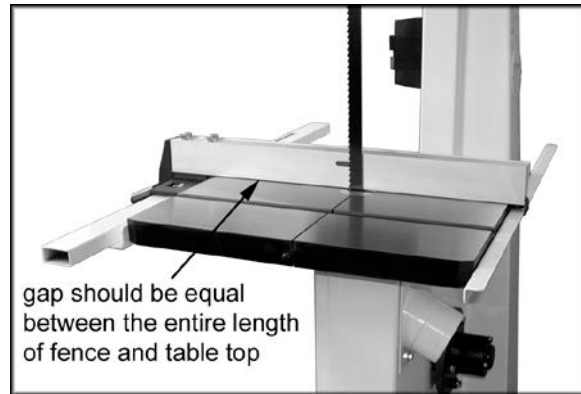

Figure 11

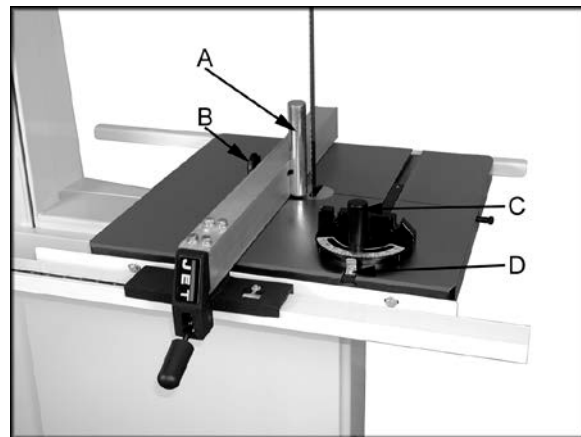

Figure 12

## Tilting the Table

1. Disconnect the machine from the power source, unplug.
2. Loosen the lock knobs (A, Fig. 13).
3. Tilt table up to 45 degrees to the right, or up to 10 degrees to the left.
4. Tighten the lock knobs.

**Note:** Table stop bolt (B, Fig. 13) must be removed to tilt table to the left.

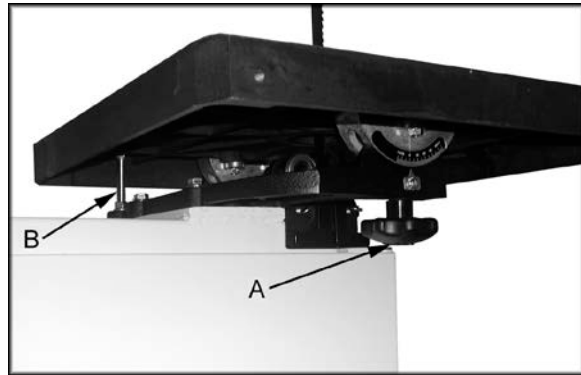

Figure 13

## Height Scale Adjustment

1. Disconnect the machine from the power source, unplug.
2. The upper blade guide should be set about 1/8" above the material to be cut.
3. Measure from the table top to the bottom of the blade guides, Figure 14.
4. Set the indicator to this measurement on the height scale. Grasp the end of the indicator (C, Fig. 15) between your finger, and thumb. Move the indicator into position.

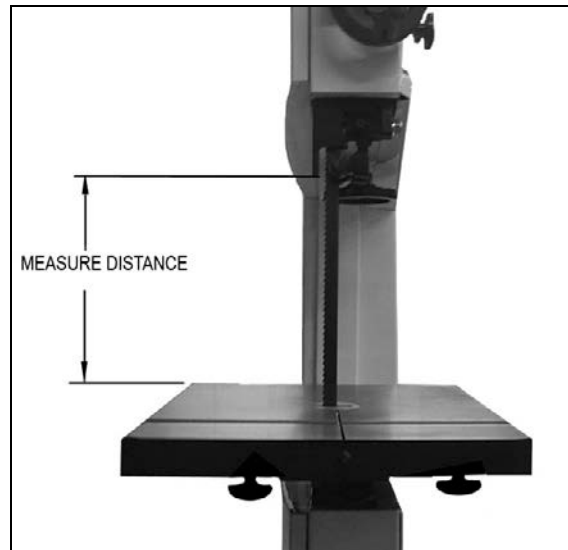

Figure 14

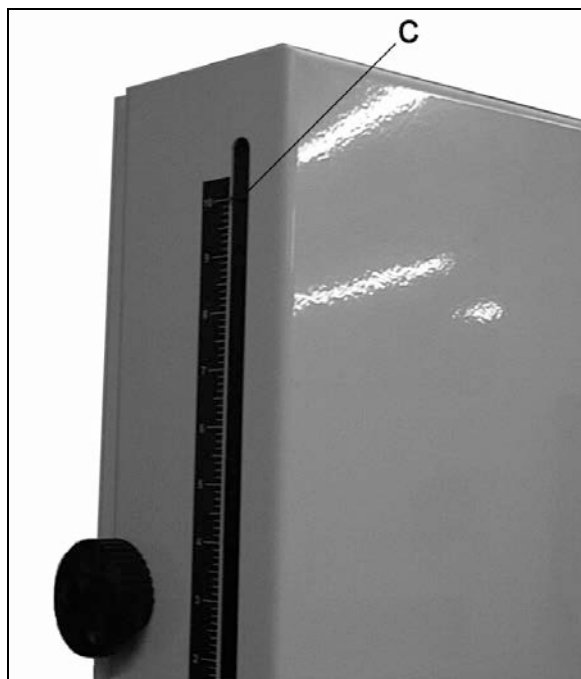

Figure 15

## Changing Blades

**⚠WARNING** Disconnect machine from the power source, unplug! Blade teeth are sharp! Use care when handling the saw blade. Failure to comply may cause serious injury!

1. Remove the table insert (A, Fig. 16), and table pin (B, Fig. 16).
2. Lower the upper blade guide assembly about half way by loosening the lock knob (F, Fig. 17) and turning the hand wheel (G, Fig. 17).
3. Loosen socket head cap screw (C, Fig. 16) and slide the blade guide assembly back as far as it will go.
4. Open both wheel covers (D, Fig. 16).
5. Loosen blade tension by turning blade tension hand wheel (E, Fig. 17) clockwise until it stops.

**Note:** You may want to wear leather work gloves while removing and handling the blade.

6. Carefully remove blade from upper and lower wheels. Remove the blade from between upper, and lower blade guides. Turn blade and direct through slot in table.
7. Make sure blade teeth point down toward table and guide the new blade through table slot. Place blade in upper, and lower blade guides.
8. Place blade in the middle of the upper and lower wheels.
9. Tension and track blade before operating saw. Find instructions for tensioning and tracking the blade on page 10 under "Adjusting Blade Tension" and "Adjusting Blade Tracking".
10. Replace table insert and table pin.

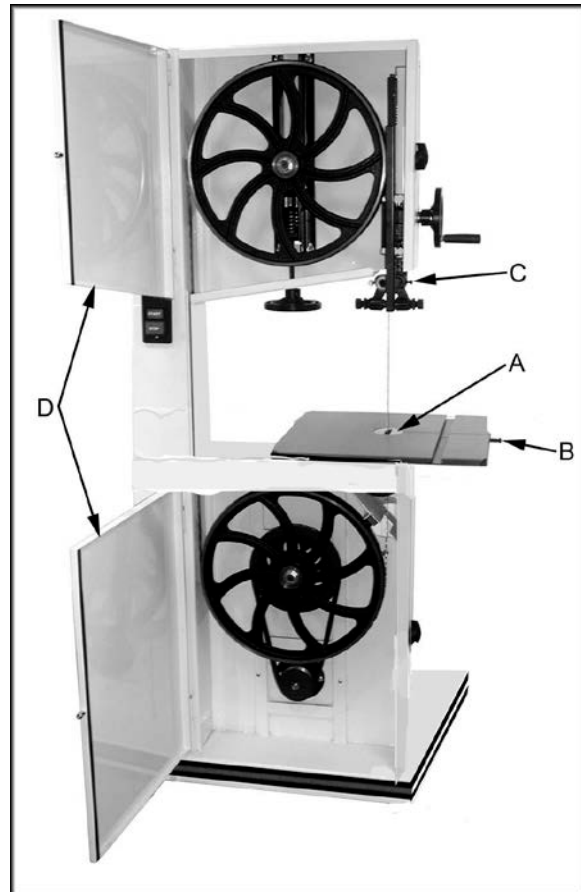

Figure 16

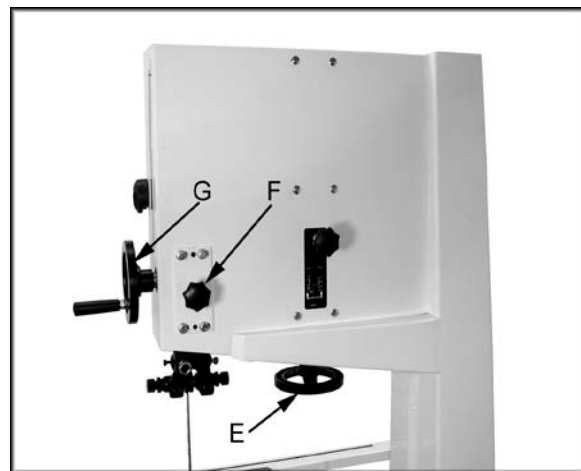

Figure 17



## Replacing V-Belt

1. Disconnect the machine from the power source.
2. Release blade tension by turning blade tension hand wheel clockwise.
3. Release belt tension by loosening the two hex cap bolts (A, Fig. 19). Raise the motor and tighten hex cap bolts to take the tension off the belt.
4. Open the lower wheel door and remove hex nut, and washer (B, Fig. 20).
5. Remove the wheel (C, Fig. 21). If the lower wheel does not come off easily you may need to use a pulley puller to remove the lower wheel.
6. Remove the old belt (D, Fig. 21) and replace the belt.
7. Reinstall the lower wheel and tighten the hex nut.
8. Loosen hex cap bolts and adjust the belt tension. See “Adjusting the Belt Tension.”
9. Set the blade tension. See “Adjusting Blade Tension” on page 10.
10. Check the blade tracking. See “Adjusting Blade Tracking” on page 10.



Figure 19

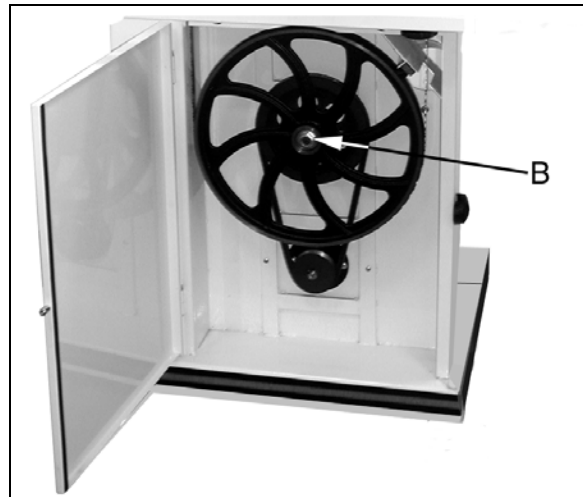

Figure 20

## Adjusting Belt Tension

The belt comes adjusted from the factory. If adjustment is needed:

1. Disconnect the machine from the power source.
2. Loosen hex cap bolts (A, Fig. 19).
3. Set the belt tension by lightly pressing down on the motor and tightening the hex cap bolts (A, Fig. 19).

**Note:** The weight of the motor should put enough tension on the belt. You just want to push down lightly to take up any slack.

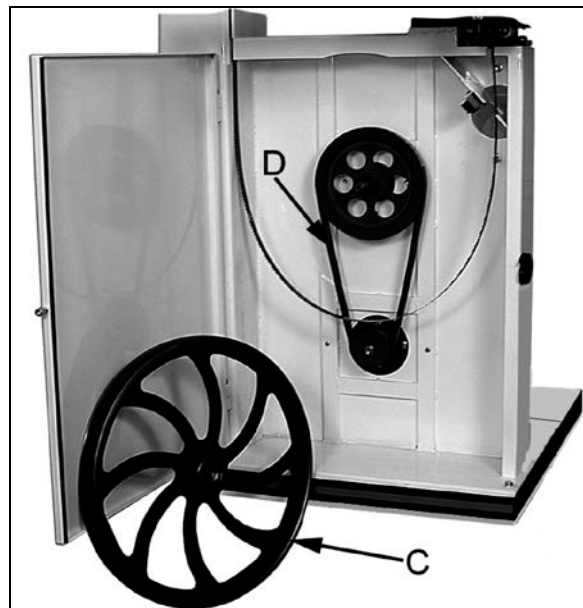

Figure 21

## Electrical Connections

**⚠WARNING** All electrical connections must be done by a qualified electrician! Failure to comply may result in loss of property and/or serious injury!

The JWBS-16B is rated at 1-1/2 HP, 1Ph, 115V/230V, prewired 115V.

The band saw comes with a 115V plug (A, Fig. 22). If you switch the motor to 230V, a plug needs to be purchased for the band saw that matches the 230V outlet you intend to use.

Confirm power at the site is the same as the saw before making any electrical connections. Review the wiring diagram on page 30.

It is recommended that the band saw, when operated on **115V**, be connected to a dedicated, *minimum* 30 amp circuit with a 30 amp circuit breaker or time delay fuse. It is recommended that the band saw, when operated on **230V**, be connected to a dedicated, *minimum* 15 amp circuit with a 15 amp circuit breaker or time delay fuse. **NOTE: Local codes take precedence over recommendations.**

Review the *Grounding Instructions, 115 Volt Operation, and 230 Volt Operation* sections on page 7.

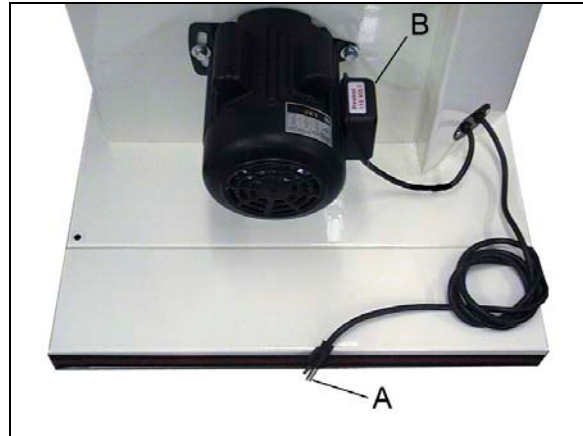

Figure 22

## Maintenance

Keep blade guides clean and free of build up.

Do not let saw dust build up in the upper and lower wheel housings. Vacuum out frequently.

Connect the band saw to a JET dust collection system.

Clean and grease the raising/lowering rack for the upper blade guides if it becomes difficult to raise, or lower.

Clean, and oil the tensioning mechanism if it becomes difficult to adjust.

Vacuum out the motor fan cover.

# Troubleshooting

Trouble	Possible Cause	Solution
Saw stops or will not start	<ol style="list-style-type: none"> <li>1. Saw unplugged</li> <li>2. Fuse blown or circuit breaker tripped</li> <li>3. Cord damaged</li> </ol>	<ol style="list-style-type: none"> <li>1. Check plug connections</li> <li>2. Replace fuse or reset circuit breaker</li> <li>3. Replace cord</li> </ol>
Does not make accurate 45° or 90° cuts	<ol style="list-style-type: none"> <li>1. Stop not adjusted correctly</li> <li>2. Angle pointer not set accurately</li> <li>3. Miter gauge out of adjustment</li> </ol>	<ol style="list-style-type: none"> <li>1. Check blade with square and adjust stop</li> <li>2. Check blade with square and adjust pointer</li> <li>3. Adjust miter gauge</li> </ol>
Blade wanders during cut	<ol style="list-style-type: none"> <li>1. Fence not aligned with blade</li> <li>2. Warped wood</li> <li>3. Excessive feed rate</li> <li>4. Incorrect blade for cut</li> <li>5. Blade tension not set properly</li> <li>6. Guides not set properly</li> </ol>	<ol style="list-style-type: none"> <li>1. Check and adjust fence</li> <li>2. Select another piece of wood</li> <li>3. Reduce feed rate</li> <li>4. Change blade to correct type</li> <li>5. Set blade tension according to blade size</li> <li>6. Review guide adjustment on pages 8</li> </ol>
Saw makes unsatisfactory cuts	<ol style="list-style-type: none"> <li>1. Dull blade</li> <li>2. Blade mounted wrong</li> <li>3. Gum or pitch on blade</li> <li>4. Incorrect blade for cut</li> <li>5. Gum or pitch on table</li> </ol>	<ol style="list-style-type: none"> <li>1. Replace blade</li> <li>2. Teeth should point down</li> <li>3. Remove blade and clean</li> <li>4. Change blade to correct type</li> <li>5. Clean table</li> </ol>
Blade does not come up to speed	<ol style="list-style-type: none"> <li>1. Extension cord too light or too long</li> <li>2. Low shop voltage</li> </ol>	<ol style="list-style-type: none"> <li>1. Replace with adequate size and length cord</li> <li>2. Contact your local electric company</li> </ol>
Saw vibrates excessively	<ol style="list-style-type: none"> <li>1. Base on uneven floor</li> <li>2. Bad V-belt</li> <li>3. Motor mount is loose</li> <li>4. Loose hardware</li> </ol>	<ol style="list-style-type: none"> <li>1. Reposition on flat, level surface</li> <li>2. Replace V-belt</li> <li>3. Tighten motor mount hardware</li> <li>4. Tighten hardware</li> </ol>

## Parts

### Replacement Parts

Replacement parts are listed on the following pages. To order parts or reach our service department, call 800-274-6848 Monday through Friday (see our website for business hours, [www.jettools.com](http://www.jettools.com)). Having the Model Number and Serial Number of your machine available when you call will allow us to serve you quickly and accurately.

## Upper Wheel Assembly

Index No.	Part No.	Description	Size	Qty
1	JWBS16B-101	Saw Body		1
2	TS-0152011	Carriage Bolt	5/16-18x1	6
3	JWBS18-103	Upper Wheel Bracket		2
4	TS-0680031	Flat Washer	5/16	6
5	TS-0720081	Lock Washer	5/16	6
6	TS-0561021	Hex Nut	5/16-18	6
7	994542	Switch		1
8	JWBS18-108	Hex Cap Bolt	M8x65	1
9	TS-0680021	Flat Washer	1/4	4
10	JWBS18-110	Sliding Bracket		1
11	JWBS18-111	Blade Tension Indicator		1
12	JWBS18-112	Adjustment Bracket		1
13	JWBS18-113	Shaft Bracket		1
14	TS-1541031	Nylon Insert Lock Nut	M8	1
15	JWBS18-115	Spring		1
16	JWBS18-116	Square Nut		1
17	JWBS18-117	Pointer		1
18	JWBS18-118	Screw	M5x8	1
19	JWBS18-119	Set Block		1
20	TS-0267021	Set Screw	1/4-20x1/4	1
21	JWBS18-121	Bracket		1
22	TS-0050021	Hex Cap Screw	1/4-20x5/8	4
23	JWBS16-123	Blade Adjusting Screw		1
24	JWBS18-124	E-Ring	E-9	1
25	JWBS18-125	Hand Wheel		1
26	TS-0267041	Socket Set Screw	1/4-20x3/8	3
27	TS-0209021	Socket Head Cap Screw	3/8-16x5/8	1
28	TS-0720091	Lock Washer	3/8	1
29	JWBS18-129	Upper Wheel Shaft		1
30	BB-6203ZZ	Ball Bearing	6203ZZ	2
31	JWBS18-131	Retaining Ring	R40	2
32	JWBS16-132	Upper Wheel		1
33	JWBS16-133	Tire		1
34	JWBS18-134	Flat Washer		1
35	JWBS18-135	Hex Nut	5/8-18UNF L.H.	1
36	JWBS16B-136	Blade	3/4"W x 123"L x .026"T x 4TPI	1
37	TS-0590061	Wing Nut	5/16-18	1
38	JWBS18-138	Lock Knob	5/16	1
39	JWBS16B-139	Upper Front Door		1
40	JWBS18-140	JET Plaque		1
41	JWBS18-141	Warning Label		1
42	JWBS18-142	Bolt		1
43	TS-0561011	Hex Nut	1/4-20	1
44	TS-081C022	Pan Head Machine Screw	#10-24x3/8	2
45	JWBS18-39A	Door Hinge Pin		1
46	JWBS18DXA-163	Blade Warning Label		1
47	TS-1550061	Flat Washer	M8	2

# Upper Wheel Assembly

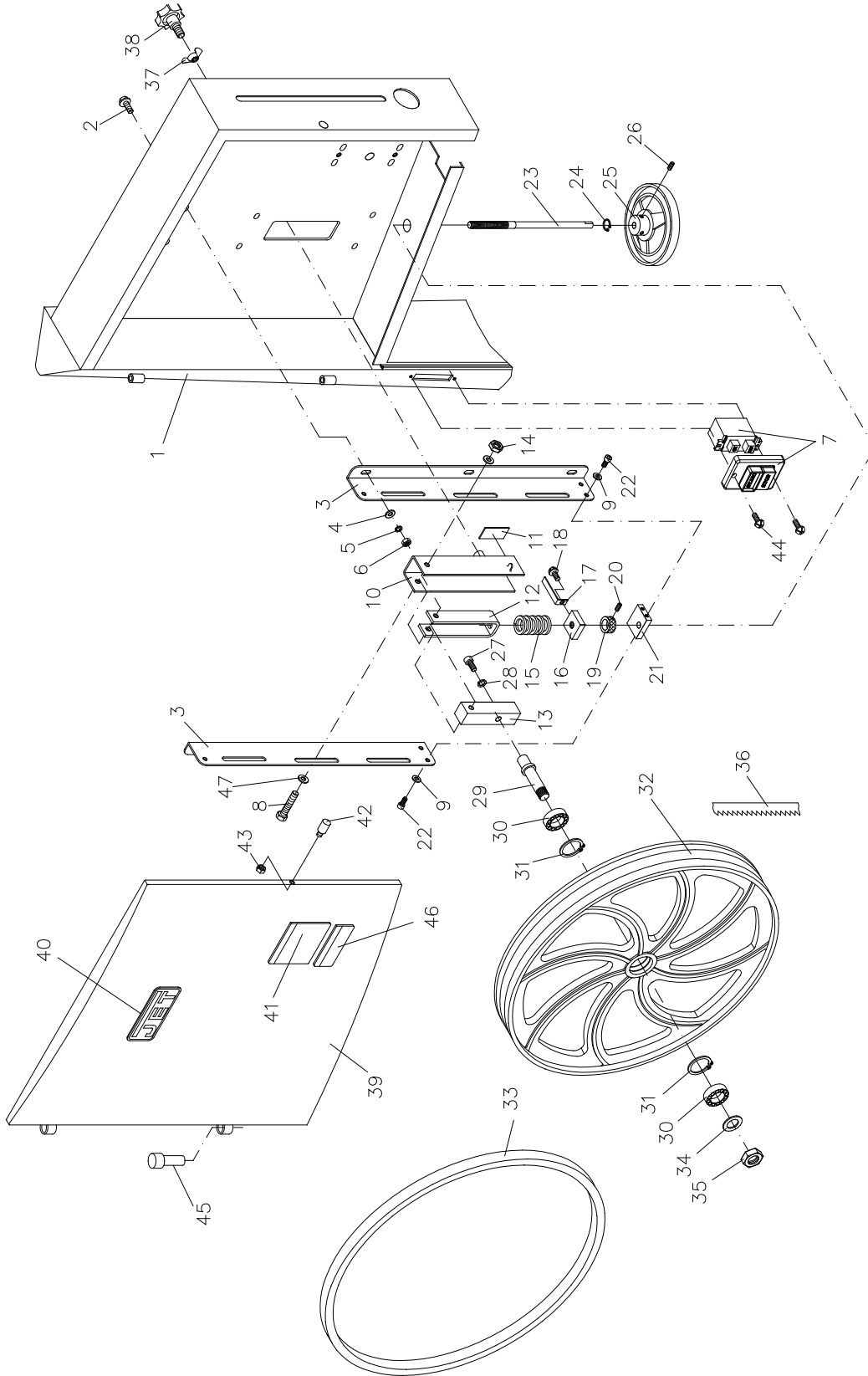

## Lower Wheel and Motor Assembly

Index No.	Part No.	Description	Size	Qty
1	JWBS18-201N	Bearing Base		1
2	JWBS20-62	Adjusting Bolt		4
3	TS-0720091	Lock Washer	3/8	4
4	TS-0060081	Hex Cap Screw	3/8-16x1-3/4	4
5	BB-6204ZZ	Ball Bearing	6204ZZ	1
6	JWBS18-206N	Spindle		1
7	JWBS18-207	Key	7x7x40	1
8	JWBS18-208N	Spindle Pulley		1
9	VB-B40	V-Belt	B-40	1
10	JWBS16-210	Lower Wheel		1
11	JWBS16-133	Tire		1
12	TS-0680081	Flat Washer	5/8	1
13	JWBS18-135	Hex Nut	5/8-18UNF L.H.	1
14	JWBS18-214	Hex Nut	5/8-18UNF R.H.	1
15	JWBS18-215	Bearing Cover		1
16	TS-0720051	Lock Washer	#10	3
17	TS-081C022	Pan Head Machine Screw	#10-24x3/8	3
18	JWBS16-218	Motor		1
	JWBS16-SC	Starting Capacitor (not shown)	200MFD, 125VAC	1
	JWBS16-RC	Running Capacitor (not shown)	16µF, 250V	1
	JWBS16-SCC	Starting Capacitor Cover (not shown)		1
	JWBS16-RCC	Running Capacitor Cover (not shown)		1
	JWBS18-FAN	Fan		1
	JWBS18-CS	Centrifugal Switch (not shown)		1
	JWBS16-MFC	Motor Fan Cover (not shown)		1
19	JWBS18-219	Motor Bracket		1
20	TS-0081031	Hex Cap Screw	5/16-18x3/4	4
21	TS-0680031	Flat Washer	5/16	4
22	TS-0060051	Hex Cap Screw	3/8-16x1	2
23	TS-0720091	Lock Washer	3/8	2
24	TS-0680041	Flat Washer	3/8	2
25	JWBS16-225	Motor Pulley		1
26	TS-0270031	Socket Set Screw	5/16-18x3/8	2
27	JWBS16B-227	Lower Front Door		1
28	JWBS18-142	Bolt		1
29	TS-0561011	Hex Nut	1/4-20	1
30	JWBS20-2	Lock Knob		1
31	TS-081F052	Pan Head Machine Screw	1/4-20x3/4	1
32	JWBS20-8W	Dust Chute		1
33	TS-0680031	Flat Washer	5/16	2
34	TS-0051051	Hex Cap Screw	5/16-18x1	2
35	JWBS18-235	Plate		1
36	TS-081C032	Pan Head Machine Screw	#10-24x1/2	2
37	JWBS18-237	Strain Relief Bushing		2
38	TS-081C082	Pan Head Machine Screw	#10-24x1-1/2	2
39	TS-069204	Flat Washer	#10	2
40	JWBS18-240	Brush		1
41	TS-0720051	Lock Washer	#10	2
42	TS-0560071	Hex Nut	#10-24	2
43	JWBS18-243	Motor Cord		1
44	JWBS18-244	Power Cord		1
45	BB-6205ZZ	Ball Bearing	6205ZZ	1
46	JWBS16B-246	I.D. Label		1
48	JWBS18-39A	Door Hinge Pin		2
49	JWBS16B-249	Base Support Foot		1
50	JWBS16B-250	Support Plate		2
51	TS-0255011	Button Head Socket Screw	5/16-18x3/8	8

# Lower Wheel and Motor Assembly

Index No.	Part No.	Description	Size	Qty
52	TS-0680031	Flat Washer	5/16	8
53	TS-0720081	Lock Washer	5/16	2
54	TS-0561021	Hex Nut	5/16-18	2

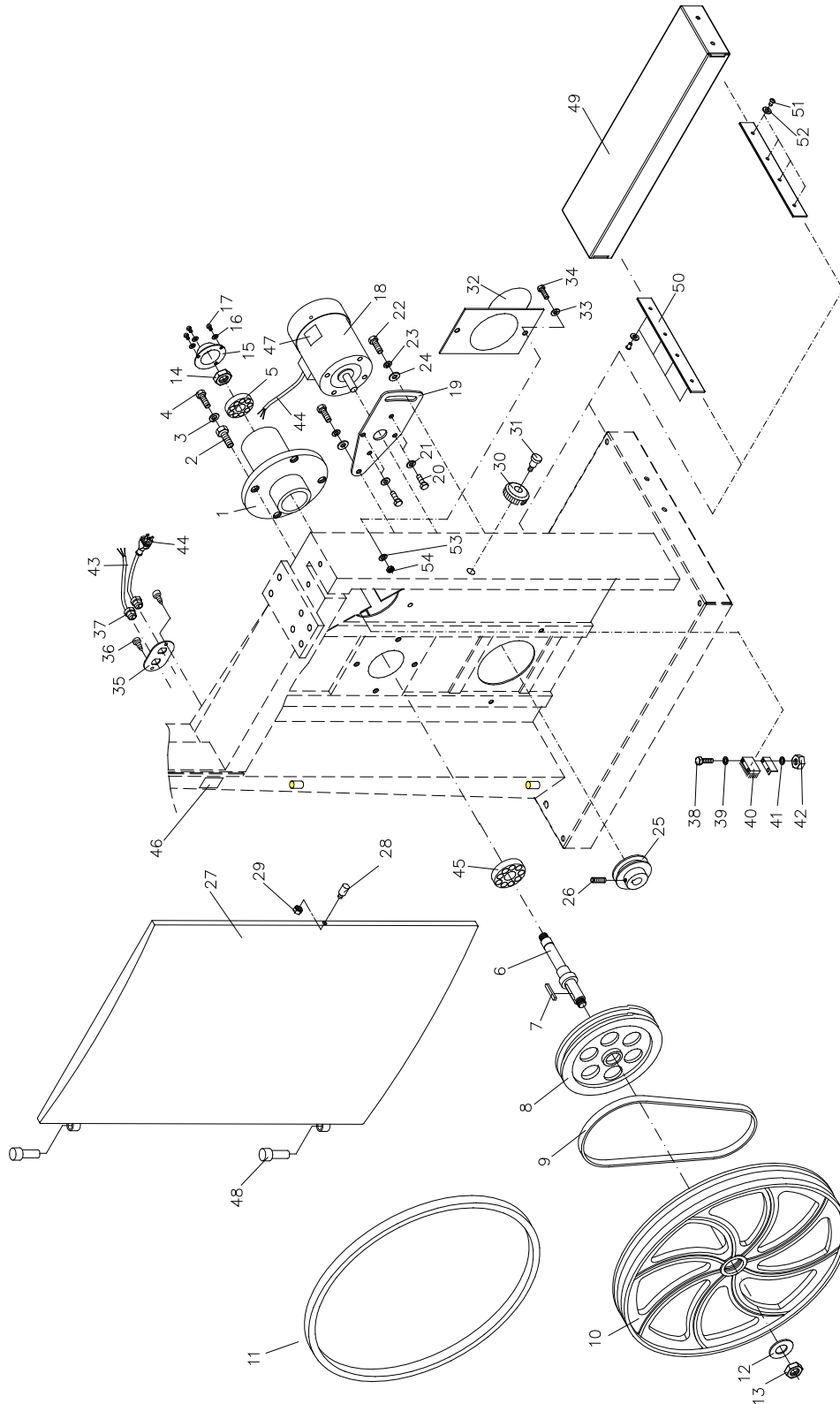

## Blade Guides Assembly

Index No.	Part No.	Description	Size	Qty
1	TS-0051051	Hex Cap Screw	5/16-18x1	4
2	TS-0720081	Lock Washer	5/16	4
3	TS-0680031	Flat Washer	5/16	8
4	JWBS18-304	Guide Bar Bracket		1
5	JWBS18-305	Worm		1
6	JWBS18-306	E-Ring	E-8	2
7	JWBS18-307	Gear Base		1
8	JWBS18-308	Bushing		1
9	JWBS18-309	C-Ring	S-12	2
10	JWBS18-310	Shaft		1
11	JWBS18-311	Gear		1
12	TS-0208071	Socket Head Cap Screw	5/16-18x1-1/4	2
13	JWBS18-313	Lock Knob	5/16	1
14	JWBS18-314	Plate		1
15	TS-0051011	Hex Cap Screw	5/16-18x1/2	4
16	JWBS18-316	Guide Bar		1
17	JWBS16B-317	Pointer		1
18	TS-0720071	Lock Washer	1/4	5
19	TS-0050011	Hex Cap Screw	1/4-20x1/2	1
20	JWBS18-320	Guide Bracket		1
21	TS-0207021	Socket Head Cap Screw	1/4-20x1/2	11
22	JWBS18-322	Blade Guard		1
23	TS-0720111	Lock Washer	1/2	1
24	TS-0561051	Hex Nut	1/2-13	1
25	JWBS20-110	Locking Shaft		1
26	JWBS20-115	Upper Guide Bracket		1
27	JWBS20-114	Guide Wheel Assembly		2
28	JWBS20-113	Blade Support Shaft w/ Bearing		2
29	JWBS18DXA-353	Wing Screw	1/4-20x1/2	4
30	TS-0270031	Socket Set Screw	5/16-18x3/8	2
31	JWBS20-2	Lock Knob		1
32	TS-081F052	Pan Head Machine Screw	1/4-20x3/4	1
33	JWBS18-333	Hand Wheel		1
34	TS-0267041	Socket Set Screw	1/4-20x3/8	1
35	JWBS20-103A	Handle		1
36	JWBS16B-336	Cutting Height Scale		1
37	JWBS20-120	Lower Guide Bracket		1
38	JWBS18-338	Lower Guide Wheel Housing		2
39	JWBS18-339	Lower Guide Wheel Assembly		2
40	TS-0207031	Socket Head Cap Screw	1/4-20x5/8	2
41	TS-0680021	Flat Washer	1/4	4
42	JWBS18-342	Lower Blade Guard		1
43	TS-0254021	Button Head Socket Screw	1/4-20x1/2	2



# Blade Guides Assembly

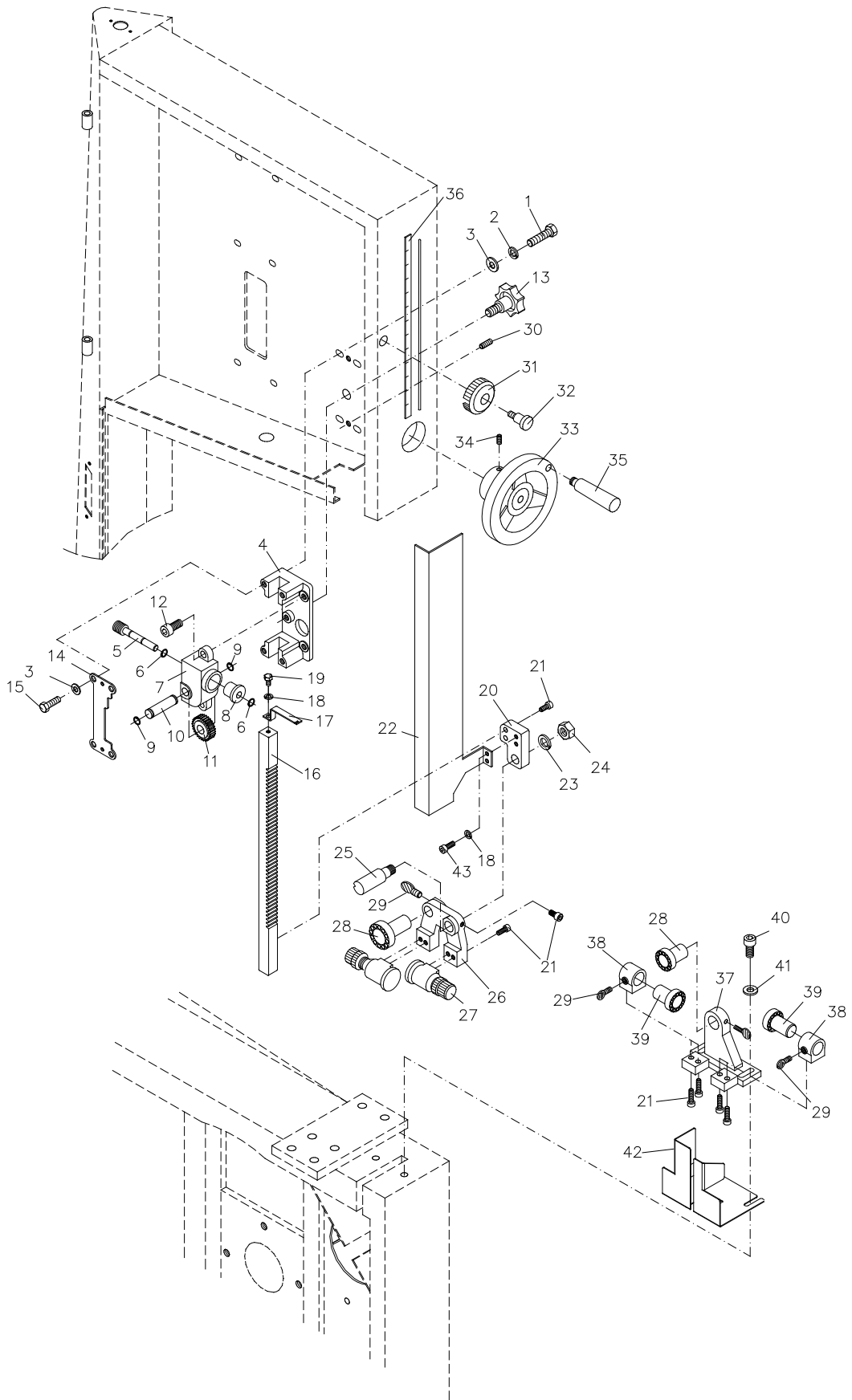

## Table Assembly

Index No.	Part No.	Description	Size	Qty
1	JWBS16-401	Table		1
2	JWBS20-144	Table Insert		1
3	JWBS20-145	Roll Pin	Ø3x10	1
4	JWBS18-448	Table Pin		1
5	JWBS18-408N	Trunnion Support Bracket		1
6	TS-0051071	Hex Cap Screw	5/16-18x1-1/2	4
7	TS-0720081	Lock Washer	5/16	4
8	TS-0270061	Set Screw	5/16-18x5/8	2
9	TS-0060111	Hex Cap Screw	3/8-16x2-1/2	1
10	TS-0561031	Hex Nut	3/8	1
11	TS-0720091	Lock Washer	3/8	1
12	JWBS18-415	Lock Knob		2
13	JWBS18-446	Pointer		1
14	JWBS18-447	Screw	M5x8	1
15	TS-1491081	Hex Cap Screw	M10x50	2
16	JWBS18-417	Trunnion Clamp Shoe		2
17	JWBS18-416	Trunnion		2
18	TS-1482021	Hex Cap Screw	M6x12	6
19	JWBS18-420	Scale		1

# Table Assembly

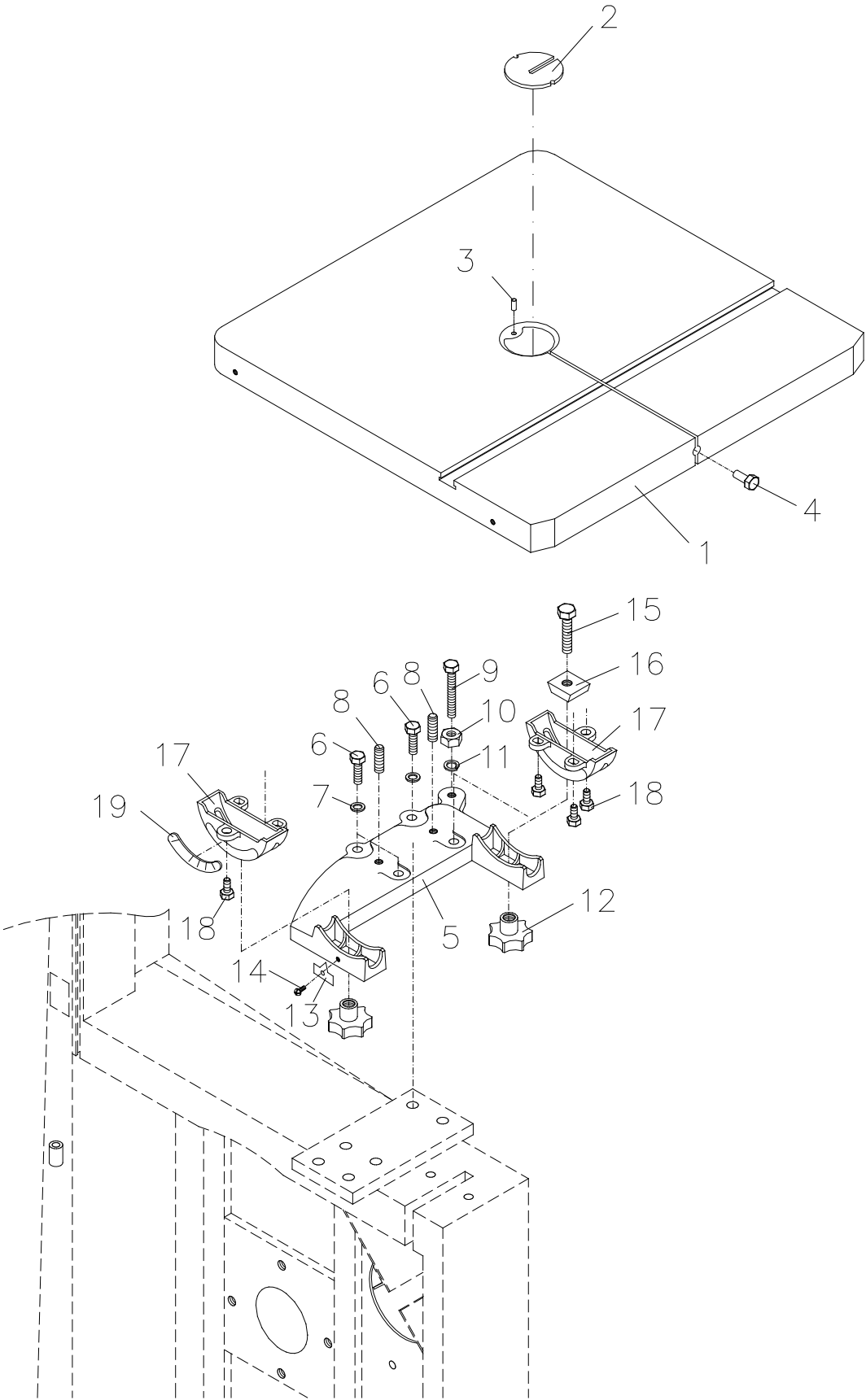

## Fence & Miter Assembly (optional accessory)

Index No.	Part No.	Description	Size	Qty
1	JWBS18-401	Lock Knob		1
2	TS-0680021	Flat Washer	1/4	11
3	JWBS18-403	Miter Gauge Body		1
4	200156	Guide Disc		1
5	JWBS18-405	Screw	M6x8	1
6	JWBS18-406	Pointer		1
7	JWBS18-407	Guide Bar		1
10	TS-0720081	Lock Washer	5/16	4
22	JWBS18-422W	Front Rail		1
23	TS-0050021	Hex Cap Screw	1/4-20x5/8	9
24	TS-0720071	Lock Washer	1/4	10
25	JWBS18-425	Scale		1
26	JWBS18-426W	Guide Rail		1
27	JWBS18-427W	Rear Rail		1
30	JWBS18-430	Fence Body		1
31	JWBS18-431	Knob		1
32	JWBS18-432	Lock Handle		1
33	JWBS18-433W	Lock Plate		1
34	JWBS18-434	Pad		5
35	JWBS18-435	Pin		1
36	JWBS18-436	Pin		1
37	JWBS16-437	Fence		1
38	TS-0081031	Hex Cap Screw	5/16-18x3/4	4
39	TS-0680031	Flat Washer	5/16	4
40	TS-0810012	Screw	#10-24x1/4	2
41	TS-0733031	External Tooth Lock Washer	#10	1
42	JWBS18-442	Pointer		1
43	TS-0561011	Hex Nut	1/4-20	2
44	JWBS18-444	Sliding Pad		1
45	JWBS18-445	Rear Hook		1
49	JWBS18-449	Resaw Post		1
50	JWBS18-450	Knob		1
51	JWBS18-451	JET Fence Label		1
52	JWBS20-455	End Cover		2
	JWBS18-MGCP	Miter Gauge Assembly		
	JWBS16-FCP	Fence Assembly Complete (contains fence, rails, resaw post and hardware bag)		

# Fence & Miter Assembly (optional accessory)

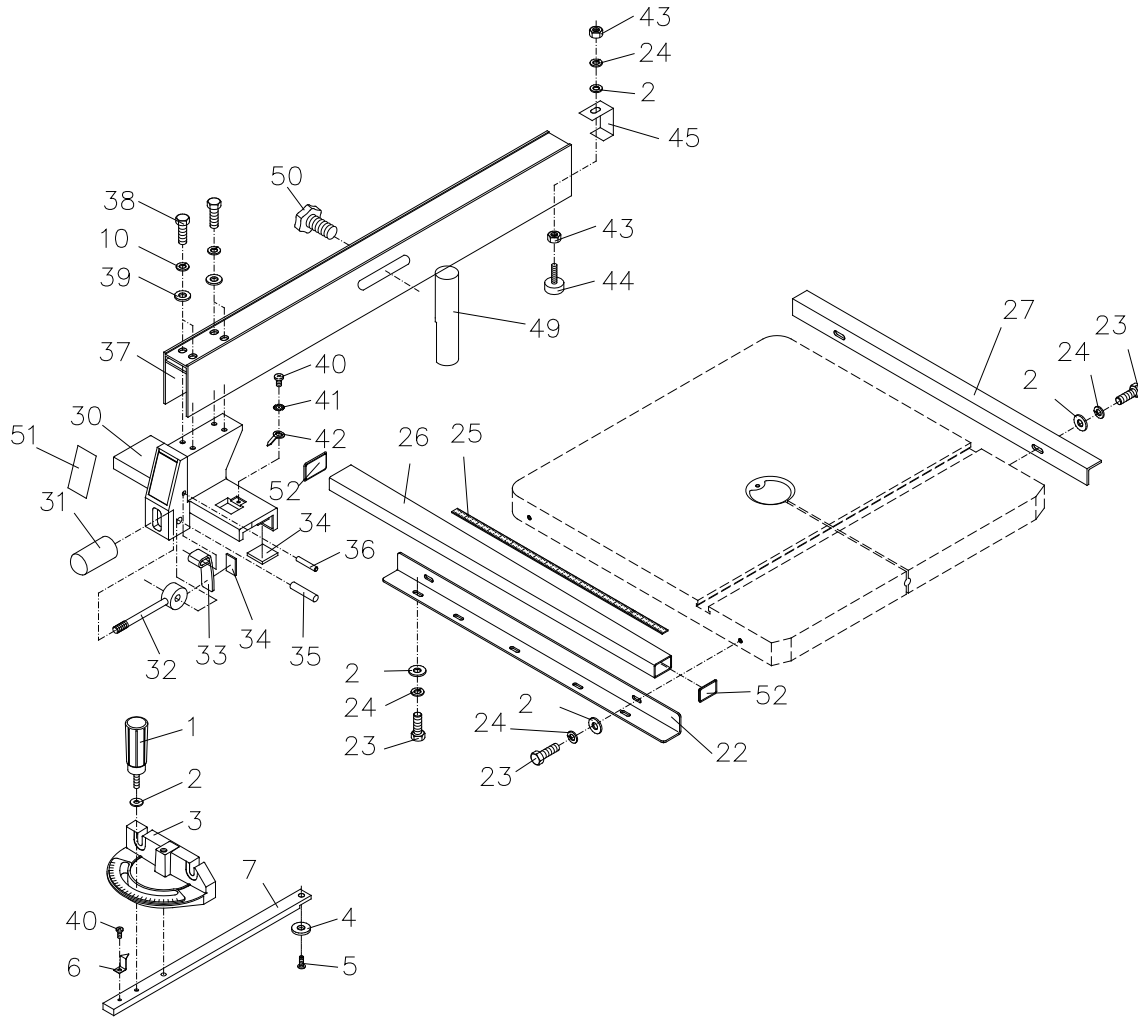

# Wiring Diagram

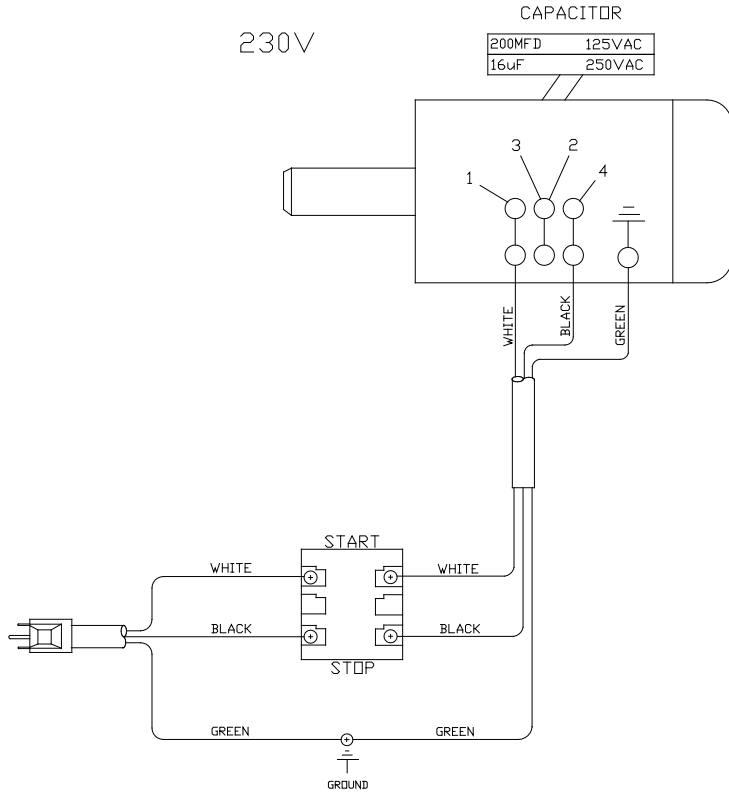
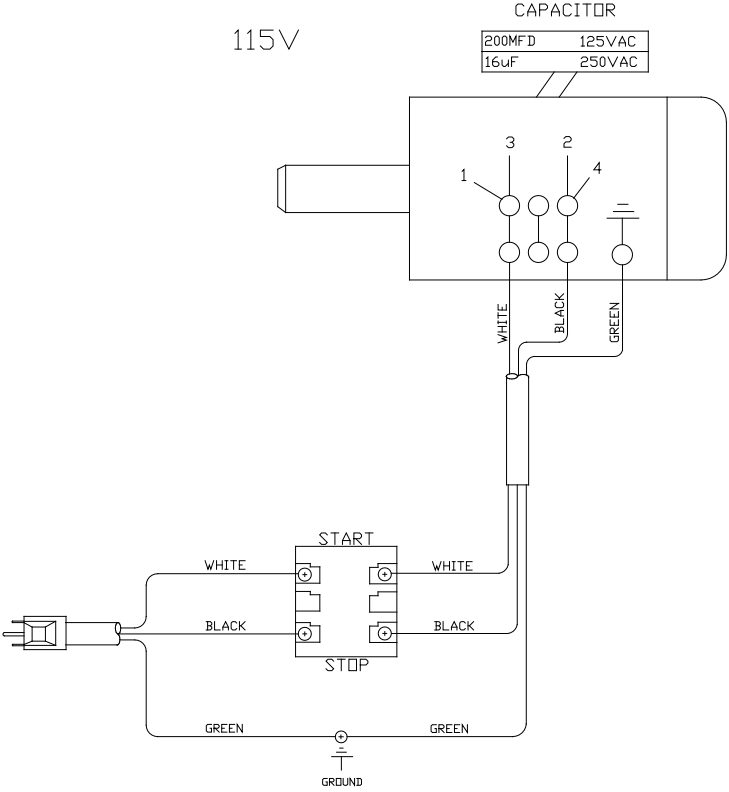

# Notes



427 New Sanford Road  
LaVergne, Tennessee 37086  
Phone: 800-274-6848  
[www.jettools.com](http://www.jettools.com)